



neptune

RML500

1/2" Mass Flowmeter for LPG



Compared to traditional mechanical flowmeters, the RML2000 offers better accuracy, higher flow rates, and outstanding stability between yearly calibrations. This performance, combined with electronic temperature compensation, significantly reduces under-measurement of LP gas.

The meter's unobstructed dual vibrating tube design has no moving parts, increasing service life and lowering maintenance costs.

The Coriolis mass flowmeter provides volumetric flow measurement of LP Gas when interfaced with an electronic register. The system's outstanding flexibility gives an upgrade path not obtainable with competitive electronic transaction management systems.

DIMENSIONS

FLANGES	A	B	C	D	WEIGHT
1/2" 300#	18.5" (469mm)	7.17" (182mm)	9.13" (232mm)	4.13" (105mm)	15lbs (7kg)
1" 300#	18.8" (476mm)	7.17" (182mm)	9.13" (232mm)	4.13" (105mm)	20lbs (9kg)

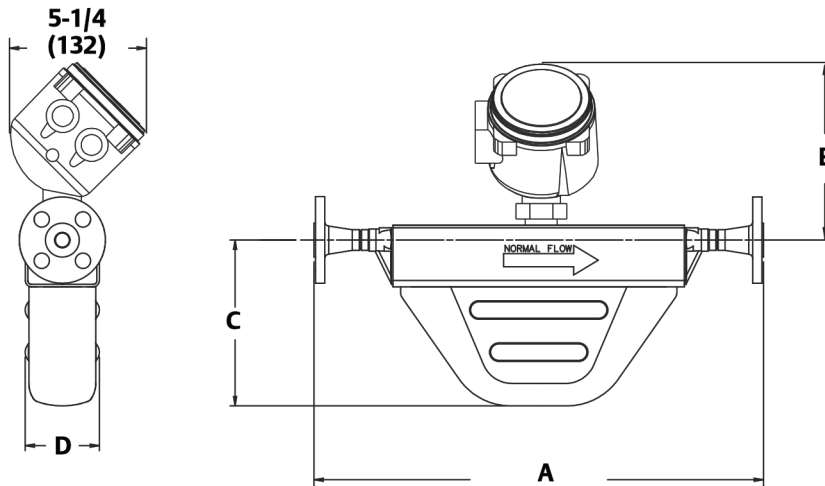

All dimensions are ±0.13" (±3mm).

Specifications

ELECTRONICS (Digital Transmitter)	
Communication Protocol	Modbus RTU

ELECTRONICS (Analog Transmitter)	
Channel A	One active or passive 4-20 mA output
Channel B	Configurable to one active or passive frequency/pulse output, discrete output, or discrete input
Service Port	For temporary connections only (requires removing transmitter housing cover) RS-485 Modbus signal 38.4 baud One stop bit No parity Address 111 (not configurable)
HART/Bell 202	HART signal is superimposed on the primary milliamp output, and is available for host system interface: <ul style="list-style-type: none"> • Frequency: 1.2 and 2.2 kHz • Amplitude: to 1.0 mA • 1200 baud, one stop bit, odd parity • Address: 0 (default), configurable • requires 250 to 600 ohm resistance

PHYSICAL	
Wetted Parts	316L stainless steel
Sensor Housing	304L stainless steel
Signal Transmitter	Aluminum
Weight (transducer only)	See Chart
Line Size	DN15 (0.5 in)

PERFORMANCE	
General Purpose Mass Flow Rate	Nominal: 155 lb/min (4226 kg/h) Maximum: 300 lb/min (8160 kg/h)
General Purpose Volume Flow Rate	Nominal: 19 g/min (4226 l/h) Maximum: 38 g/min (8160 l/h)
Mass Flow Accuracy	Basic: $\pm 0.2\%$ of rate Enhanced: $\pm 0.1\%$ of rate
Mass Flow Repeatability	Basic: $\pm 0.1\%$ of rate Enhanced: $\pm 0.05\%$ of rate
Mass Zero Stability	0.327 kg/hr (0.012 lb/min)
Volume Flow Accuracy	Basic: $\pm 0.2\%$ of rate Enhanced: $\pm 0.1\%$ of rate
Volume Flow Repeatability	Basic: $\pm 0.1\%$ of rate Enhanced: $\pm 0.05\%$ of rate
Density Accuracy	Basic: ± 0.002 g/cm ³ (± 2.0 kg/m ³) Enhanced: ± 0.001 g/cm ³ (± 1.0 kg/m ³)
Density Repeatability	Basic: ± 0.001 g/cm ³ (± 1.0 kg/m ³) Enhanced: ± 0.0005 g/cm ³ (± 0.5 kg/m ³)
Temperature Accuracy	$\pm 1^\circ\text{C} \pm 0.5\%$ of reading
Temperature Repeatability	$\pm 0.2^\circ\text{C}$

ENVIRONMENTAL	
Temperature range (E4000 Register)1	There is no ambient temperature limit for the transducer. Refer to register specifications.
Pressure rating (case) (sensor)	26 bar (383 psi) 100 bar (1450 psi)

APPROVALS	
Weights and Measures	Pending
Measurement Canada	Pending
UL and CSA	Pending

1310 Emerald Road
Greenwood, SC 29646
USA
Phone: 1.800.833.3357
Fax: 1.864.223.0341

