

# BLACKMER LB COMPRESSORS

960474

INSTRUCTIONS NO. 588/A

## Installation, Operation, and Maintenance Instructions

Section	502
Effective	Nov 2004
Replaces	July 2004

**MODELS: LB161B, LB361B, LB601B  
LB162B, LB362C, LB602B**

### TABLE OF CONTENTS

<b>SAFETY DATA</b> .....	1	<b>OPERATION</b>	
<b>GENERAL INFORMATION</b>		Pre-Start up Check List .....	9
Compressor Data .....	2	Start Up Procedure .....	10
Nameplate Data .....	3	<b>MAINTENANCE</b>	
Maximizing Compressor Life.....	4	Service Schedule.....	11
<b>INSTALLATION</b>		Tool List.....	11
Location and Piping.....	5	Bolt Torque Table .....	12
Mounting the Compressor Unit.....	5	Crankcase Lubrication.....	12
Stationary Compressors.....	5	Setting the Oil Pressure.....	12
Truck Mounted Compressors .....	5	<b>COMPRESSOR DISASSEMBLY</b> .....	13
Compressor Flywheel .....	6	<b>COMPRESSOR ASSEMBLY</b> .....	14
V-Belt Drive.....	6	<b>VALVE REPLACEMENT</b> .....	16
PTO Drive.....	6	<b>SEAL (PACKING) REPLACEMENT</b> .....	18
Liquefied Gas Transfer Piping Schematic.....	7	<b>BEARING REPLACEMENT</b> .....	19
Typical Transfer Compressor, Drawing.....	7	<b>OIL PUMP REPLACEMENT</b> .....	20
Relief Valves.....	8	<b>EXTENDED STORAGE</b> .....	20
4-Way Valves .....	8	<b>TROUBLESHOOTING</b> .....	21
Liquid Traps.....	8		
Temperature and Pressure Switches .....	8 & 9		
Pressure Gauges .....	9		

### SAFETY DATA



This is a SAFETY ALERT SYMBOL.

When you see this symbol on the product, or in the manual, look for one of the following signal words and be alert to the potential for personal injury or property damage.



Warns of hazards that WILL cause serious personal injury, death or major property damage.



Warns of hazards that CAN cause serious personal injury, death or major property damage.



Warns of hazards that CAN cause personal injury, or property damage.

#### NOTICE

Indicates special instructions which are very important and must be followed.

### NOTICE

Blackmer compressors **MUST** only be installed in systems which have been designed by qualified engineering personnel. The system **MUST** conform to all applicable local and national regulations and safety standards.

These instructions are intended to assist in the installation and operation of Blackmer compressors and **MUST** be kept with the compressor.

Blackmer compressor service and maintenance shall be performed by qualified technicians **ONLY**. Service and maintenance shall conform to all applicable local and national regulations and safety standards.

Thoroughly review this manual, all instructions and hazard warnings, **BEFORE** performing any work on the compressor.

Maintain **ALL** system and compressor operation and hazard warning decals.

For handling liquefied gas, NFPA Pamphlet 58 should be consulted.



## SAFETY DATA

**⚠ DANGER**



Flammable gas can cause death, serious personal injury or property damage

**FLAMMABLE GAS AND/OR LIQUID CAN FORM EXPLOSIVE MIXTURES WITH AIR CAUSING PROPERTY DAMAGE, SERIOUS PERSONAL INJURY OR DEATH**

**⚠ WARNING**



Hazardous pressure can cause serious personal injury or property damage

**FAILURE TO RELIEVE SYSTEM PRESSURE PRIOR TO PERFORMING COMPRESSOR SERVICE OR MAINTENANCE CAN CAUSE SERIOUS PERSONAL INJURY OR PROPERTY DAMAGE.**

**⚠ WARNING**



Hazardous machinery can cause serious personal injury.

**FAILURE TO DISCONNECT AND LOCKOUT ELECTRICAL POWER OR ENGINE DRIVE BEFORE ATTEMPTING MAINTENANCE CAN CAUSE SEVERE PERSONAL INJURY OR DEATH**

**⚠ WARNING**



Hazardous voltage. Can shock, burn or cause death.

**FAILURE TO DISCONNECT AND LOCKOUT ELECTRICAL POWER BEFORE ATTEMPTING MAINTENANCE CAN CAUSE SHOCK, BURNS OR DEATH**

**⚠ WARNING**



Hazardous or toxic fluids can cause serious injury.

**IF HANDLING HAZARDOUS OR TOXIC FLUIDS, SYSTEM MUST BE FLUSHED AND DECONTAMINATED, INSIDE AND OUT, PRIOR TO PERFORMING SERVICE OR MAINTENANCE**

**⚠ WARNING**



Hazardous pressure can cause serious personal injury or property damage

**DISCONNECTING FLUID OR PRESSURE CONTAINMENT COMPONENTS DURING COMPRESSOR OPERATION CAN CAUSE SERIOUS PERSONAL INJURY, DEATH OR MAJOR PROPERTY DAMAGE**

**⚠ WARNING**



Hazardous gases can cause property damage, personal injury or death

**EXPLOSIVE GAS CAN CAUSE PROPERTY DAMAGE, PERSONAL INJURY, OR DEATH.**

**⚠ CAUTION**



Extreme Heat can cause personal injury or property damage

**EXTREME HEAT CAN CAUSE PERSONAL INJURY OR PROPERTY DAMAGE**

## GENERAL INFORMATION

### Compressor Data

The models listed are single-stage, vertical, air-cooled reciprocating style compressors with single acting cylinders.

	Single-Seal Models Double-Seal Models	<b>LB161B</b> <b>LB162B</b>	<b>LB361B</b> <b>LB362C</b>	<b>LB601B</b> <b>LB602B</b>
Minimum / Maximum RPM *		350 / 825	350 / 825	350 / 790
		Reduce maximum speeds by 9% for continuous duty operation.		
Displacement @ min rpm - CFM (m <sup>3</sup> /hr) @ max rpm - CFM (m <sup>3</sup> /hr)		7.16 (12.2) 16.9 (28.7)	15.3 (26.0) 36.0 (61.2)	27.2 (46.3) 61.5 (104.5)
Max. BHP (kw)		10 (7.5)	15 (11)	40 (30)
MAWP - psia (kPa)		350 (2,413)		
Maximum Discharge Temperature		350°F (176°C)		
Rotation Direction		Bi-Directional		

**Table 1 - Compressor Data**

## GENERAL INFORMATION

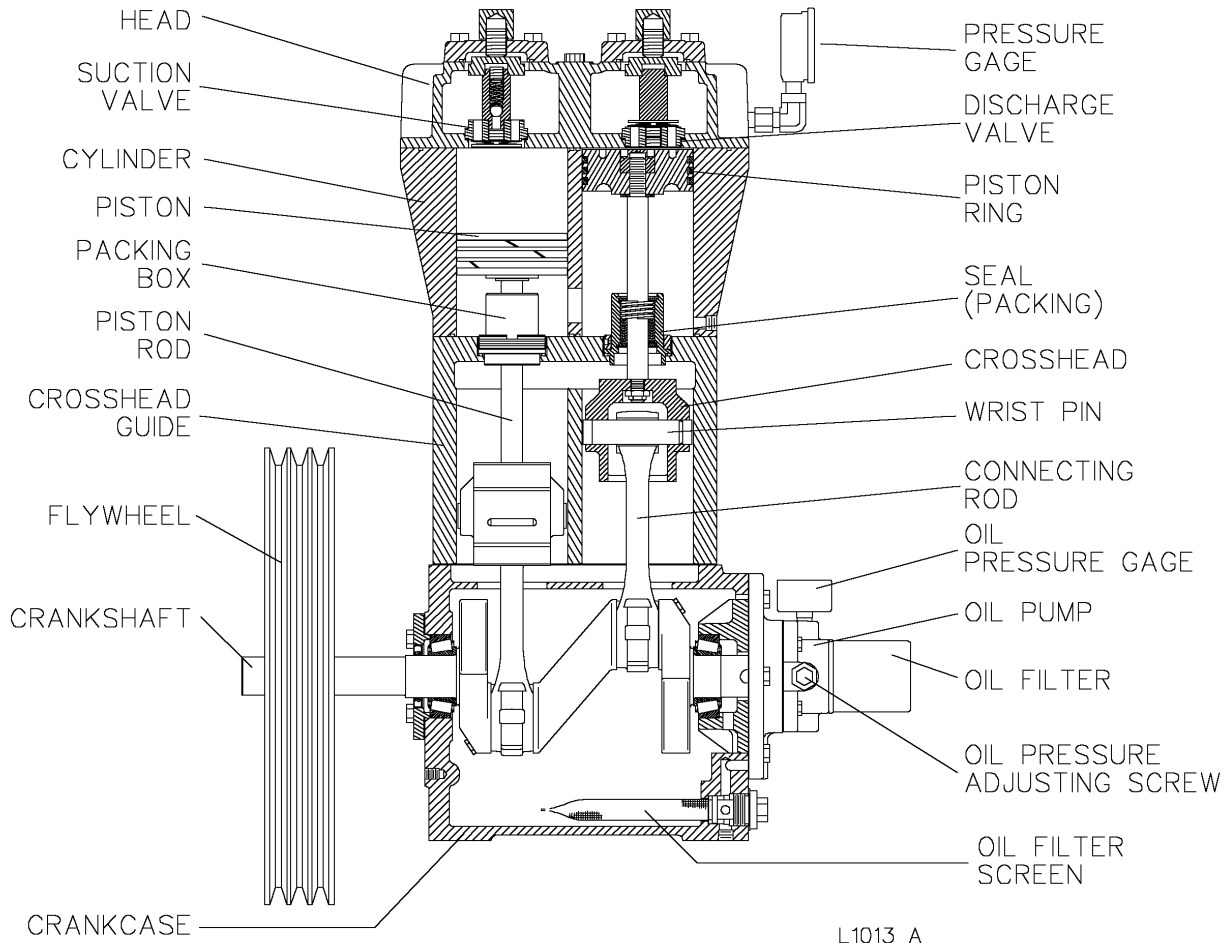

**Figure 1 - Typical Compressor**

MODEL: LB ID#: \_\_\_\_\_ SERIAL NO: \_\_\_\_\_

Before proceeding:

1. Note the nameplate data in the space provided above.
2. Obtain the appropriate parts lists for the model in question.

Manuals and Parts Lists for Blackmer products may be obtained from  
Blackmer's website ([www.blackmer.com](http://www.blackmer.com)) or be contacting Blackmer's Customer Service.

### NAMEPLATE DATA

A nameplate is attached to the side of all Blackmer compressors showing the Model No., I.D. No., and Serial No. These numbers should be available when information or parts are needed for a particular unit.

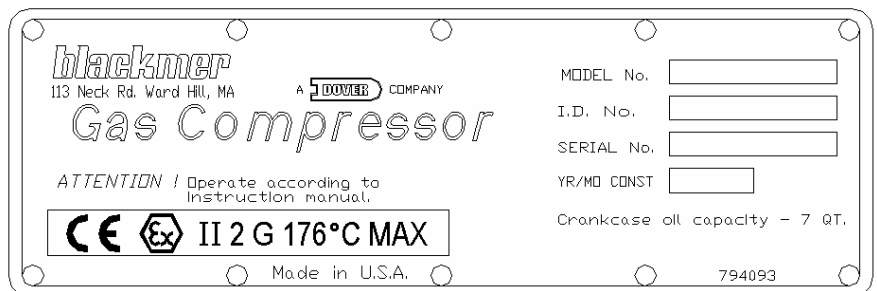

**Figure 2 - Compressor Nameplate**

The basic size and type of the compressor is indicated by "Model No." A suffix letter is used on most models to indicate the version.



## GENERAL INFORMATION

On new installations, it is suggested that the valves and piston rings be inspected after the first few hundred hours of operation. This will give an early indication of any abnormal problems and allow for

corrective action to be taken before a costly failure results. Although piston ring life will vary from application to application, wear will be fairly consistent on subsequent sets of rings.

## INSTALLATION

### NOTICE:

**BLACKMER COMPRESSORS MUST ONLY BE INSTALLED IN SYSTEMS DESIGNED BY QUALIFIED ENGINEERING PERSONNEL. SYSTEM DESIGN MUST CONFORM WITH ALL APPLICABLE REGULATIONS AND CODES AND PROVIDE WARNING OF ALL SYSTEM HAZARDS.**

### NOTICE:

**THIS COMPRESSOR SHALL BE INSTALLED IN ACCORDANCE WITH THE REQUIREMENTS OF NFPA 58 AND ALL APPLICABLE LOCAL, STATE AND NATIONAL REGULATIONS.**

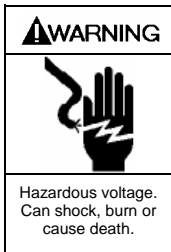

- ⚠ Install, ground and wire to local and National Electrical Code requirements.
- ⚠ Install an all-leg disconnect switch near the unit motor.
- ⚠ Disconnect and lockout electrical power before installation or service

- ⚠ Electrical supply **MUST** match motor nameplate specifications.
- ⚠ Motors equipped with thermal protection automatically disconnect motor electrical circuit when overload exists. Motor can start unexpectedly and without warning.

### LOCATION AND PIPING

Compressor life and performance can be significantly reduced when installed in an improperly designed system. Before starting layout and installation of the piping system, consider the following:

1. All piping must be leak free to a pressure of 1.5 times the maximum system pressure.

**NOTICE: If the system is to be hydro-statically tested, the compressor MUST be isolated. Liquid entering the compressor will cause damage and void the warranty.**

2. A strainer should be installed in the inlet line to protect the compressor from foreign matter. A #30 mesh screen or finer is recommended. Strainers **must** be cleaned every 180 days, or more frequently if the system requires.
3. Expansion joints, placed within 36" (0.9 m) of the compressor, will compensate for expansion and contraction of the pipes. Contact the flexible connector/hose manufacturer for required maintenance/care and design assistance in their use.
4. Piping **must** be adequately supported to ensure that no piping loads are placed upon the compressor.

5. Both suction and discharge piping should slope down from the compressor. The compressor should not be placed at a low point in the piping system.



**DISCHARGE PIPING SURFACE TEMPERATURES MAY BE HOT DURING OPERATION (OVER 158°F, 70°C). TEMPERATURES SHOULD BE MONITORED AND ADEQUATE WARNINGS POSTED.**

### MOUNTING THE COMPRESSOR UNIT

#### Stationary Compressors

A solid foundation reduces noise and vibration, and will improve compressor performance.

On permanent installations, it is recommended the compressor be secured by anchor bolts as shown. This arrangement allows for slight shifting of position to accommodate alignment with the mounting holes in the base plate.

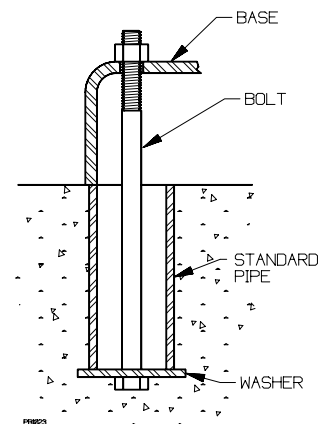

**Figure 3 - Anchor Bolt**

Set the anchor bolts in concrete for new foundations. When compressors are to be located on existing concrete floors, holes should be drilled into the concrete to hold the anchor bolts.

To keep vibration at a minimum, in addition to a solid concrete foundation, it is important that the concrete be located on a stable soil foundation. The base must have complete contact along its entire length with the foundation. Visible separations will result in vibrations which are magnified in the upper part of the unit.

#### Truck Mounted Compressors

Blackmer compressors may be mounted to the frame rails of a truck/transport and driven by either a V-belt or PTO drive.

The compressor should be solidly mounted and care should be taken to ensure that the dipstick and inspections plates are readily accessible.

Check compressor mounting bolts and baseplate anchor bolts regularly.

# INSTALLATION

## COMPRESSOR FLYWHEEL

Blackmer compressors are fitted with flywheels which **MUST** be used regardless of the type of drive system employed.

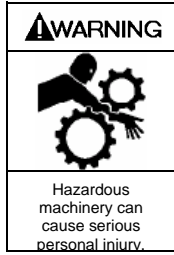

**FAILURE TO DISCONNECT AND LOCKOUT ELECTRICAL POWER OR ENGINE DRIVE BEFORE ATTEMPTING MAINTENANCE CAN CAUSE SEVERE PERSONAL INJURY OR DEATH**

Flywheels must be properly installed and aligned:

1. Ensure that the mating surface between the hub and flywheel are clean and dry – do not use a lubricant.
2. Install the hub and key on clean compressor shaft, flange end first.
3. Tighten the hub setscrew just enough to prevent it from sliding on the shaft – do not overtighten.
4. Place the flywheel on the hub and loosely thread the capscrews with lockwashers into the assembly. Do not use lubricant on the capscrews.
5. Tighten all capscrews evenly and progressively in rotation to the torque value in Table 4. There must be a gap between the hub flange and the flywheel with installation is complete. **DO NOT OVERTORQUE. DO NOT ATTEMPT TO CLOSE GAP BETWEEN HUB FLANGE AND FLYWHEEL.**

Hub Size	Capscrew Size	Torque ft-lbs. (Nm)
SF	3/8 – 16	30 (40.7)
E	1/2 - 13	60 (81)
F	9/16 – 12	110 (149)

**Table 4 – Flywheel Hub Torque Values**

6. Ensure that the radial and axial runout values at the rim do not exceed the following values:  
Radial O.D. Runout: 0.016 in. (0.4046 mm)  
Axial Rim Runout: 0.021 in. (0.5334 mm)
7. Ensure that the compressor flywheel guard is properly installed before operation. The guard must not contact moving parts.

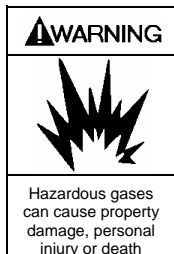

**FLYWHEEL GUARD CONTACT WITH MOVING PARTS MAY BE A SOURCE OF IGNITION IN EXPLOSIVE ATMOSPHERES CAUSING SEVERE PERSONAL INJURY OR DEATH**

## V-BELT DRIVES

Most Blackmer compressors are driven via V-belts which must be properly aligned and tensioned.

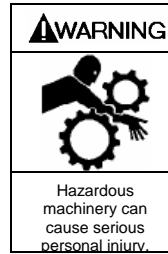

**FAILURE TO DISCONNECT AND LOCKOUT ELECTRICAL POWER OR ENGINE DRIVE BEFORE ATTEMPTING MAINTENANCE CAN CAUSE SEVERE PERSONAL INJURY OR DEATH**

1. Lay a straight edge along the face of the motor sheave and compressor flywheel.
2. Adjust either as needed to provide alignment.
3. Tighten the V-belts such that they are taut, but not overly tight. Moderate thumb pressure should deflect each belt about 1/4 – 3/8 in. (6 – 10 mm). Consult your V-belt supplier for specific values.
4. Check the belt tension after 24 - 48 hours run-in. Recheck the tension periodically, and tighten the belts as required.

Caution should be used to avoid overtightening belts, which can shorten bearing and belt life. Belts should be inspected periodically for signs of excessive wear and replaced if necessary.

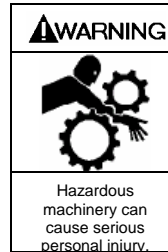

**OPERATION WITHOUT GUARDS IN PLACE CAN CAUSE SERIOUS PERSONAL INJURY, MAJOR PROPERTY DAMAGE OR DEATH.**

## PTO DRIVES

Truck mounted Compressors may be driven by the power take-off through a jackshaft connected by universal joints. The compressor must be fitted with an optional extended crankshaft to use a PTO drive without removing the flywheel. Proper PTO installation is essential:

1. Compressor shaft and PTO shaft must be parallel.
2. The yokes at the end of the jackshaft must be parallel and in phase.
3. The angle between two shafts must not exceed 15°.
4. An **EVEN** number of U-joints must be used.
5. PTO shafts **MUST** have guards installed.

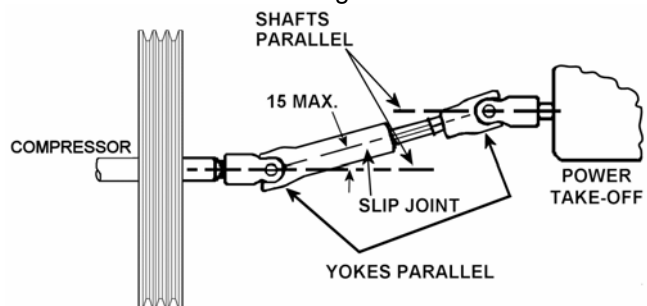

# INSTALLATION

**Figure 4 -  
Liquid Transfer  
Flow Schematic**

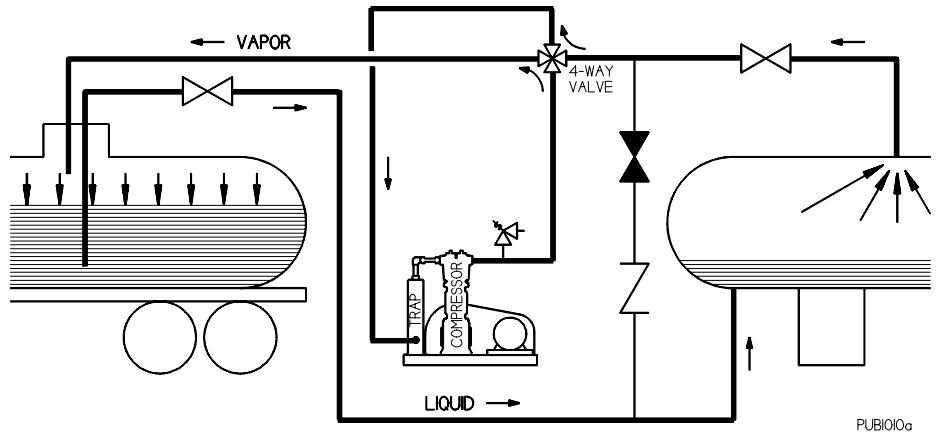

**Figure 5 -  
Vapor Recovery  
Flow Schematic**

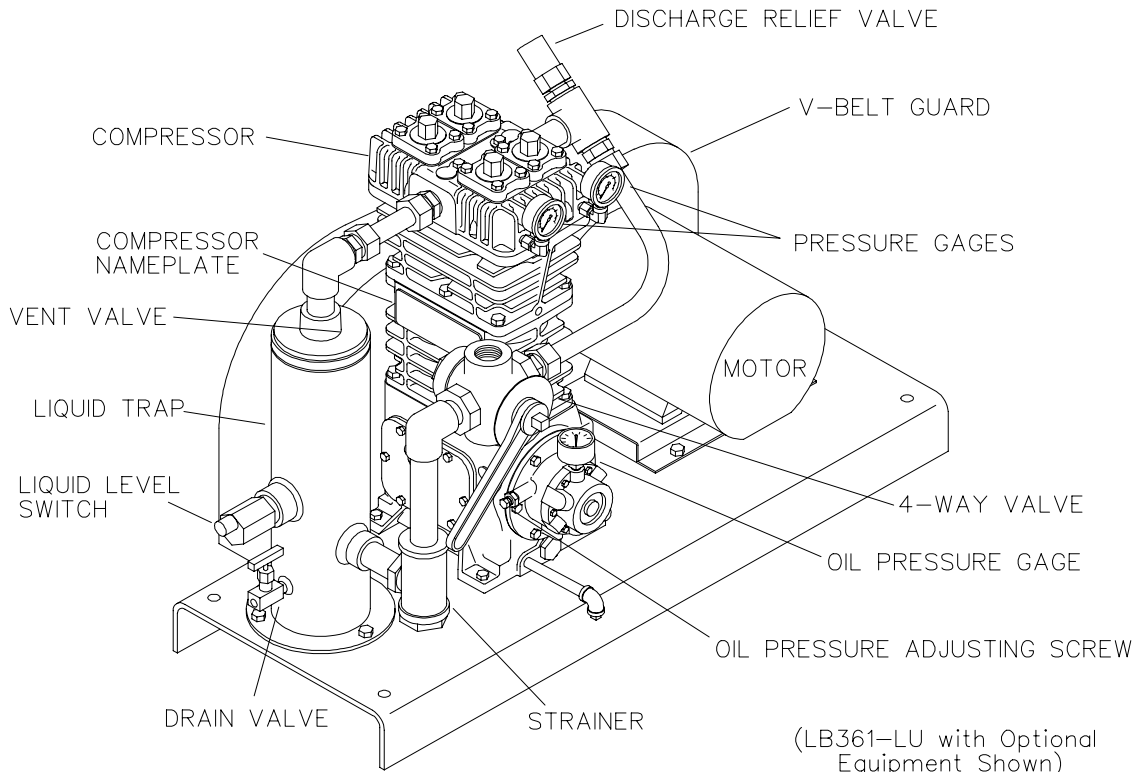
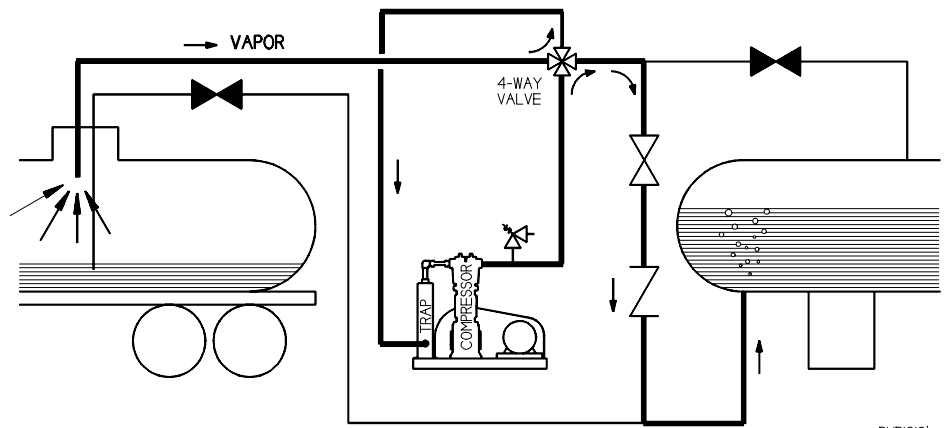

**Figure 6 - Typical Liquefied Gas Transfer Compressor**



## INSTALLATION

### RELIEF VALVES

A relief valve of a type, material and pressure rating suitable to the installation, **MUST** be installed. The relief valve shall be installed in the discharge line between the compressor head and the first block valve.

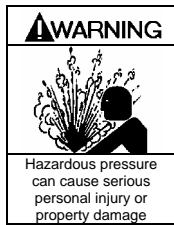

**COMPRESOR OPERATING AGAINST CLOSED VALVE CAN CAUSE SYSTEM COMPONENT FAILURE, PERSONAL INJURY OR PROPERTY DAMAGE.**

Since all systems differ in design, care must be taken to ensure the relief valve is installed to safely vent away from sources of ignition and personnel. This can be accomplished by either orientation or a pipe away, consult the Relief Valve manufacture for assistance.

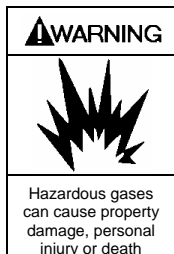

**OPERATION OF THE RELIEF VALVE CAN RELEASE EXPLOSIVE GAS TO THE ATMOSPHERE CREATING AN EXPLOSION HAZARD, POSSIBLY CAUSING PERSONAL INJURY OR DEATH**

Should the Relief Valve actuate, the cause **MUST** be determined and corrected before continuing operations. See the 'Troubleshooting' section.

Blackmer offers various relief valves for gas compatibility:

- Brass for LP-Gas service
- Aluminum for anhydrous ammonia
- Steel, A.S.M.E. code stamped for both services, and other applications.

### LIQUID TRAPS

Compressors handling gasses containing condensates or other liquids **MUST** be protected from entry of the liquid. Liquid can also enter the compressor from the discharge piping, particularly if the piping slopes down toward the compressor. To prevent liquid from entering the compressor and causing major damage, it is necessary to carefully consider the system design and have strict procedures for operation.

**NOTICE: Liquid in the compressor cylinder can cause destruction of the compressor.**

Blackmer offers a variety of liquid traps. The most common variations include:

1. A non-code vessel fitted with a stainless steel float which will shut off the intake line to the compressor in the event of an excessive liquid level. A vacuum breaking valve is provided on the liquid trap head in case the trap closes and a vacuum develops between the compressor and the trap. A manual drain valve is provided.

2. The above trap is fitted with an port allowing the use of an electric float switch which protects the compressor by stopping the compressor when a high liquid level is present in the liquid trap. The electric float switch may be used with or without the mechanical float described above.

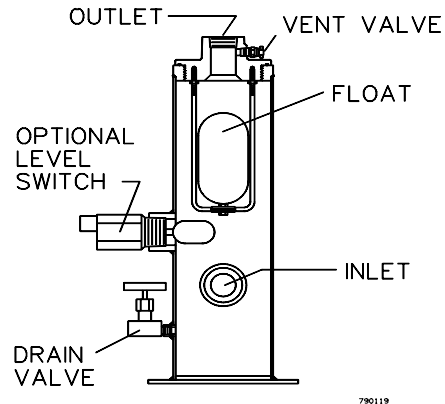

Figure 7 - Typical Liquid Trap

3. For additional protection, a larger ASME code stamped vessel is available. This liquid trap is typically fitted with one or two electric float switches for both a high liquid level shut down and alarm signal, a relief valve, and a manual drain valve. Level gauges and automatic drain systems are available options.

### 4-WAY VALVES

Many liquefied gas compressors are used for both liquid transfer and vapor recovery operations. An optional 4-way valve is used to reverse the direction of flow through the system when changing from liquid transfer to vapor recovery. Both lubricated and nonlubricated models are available. Lubricated models should be lubricated every 6 months.

### TEMPERATURE SWITCHES

Excessive discharge temperature is a leading cause of premature component failure and is often an early warning sign of impending problems.

Optional temperature switches should be installed with a thermowell as close to the compressor discharge as possible. The switch should be set to actuate at a temperature just above the maximum operating temperature of the compressor.

### LOW OIL PRESSURE SWITCHES

Loss of crankcase oil pressure is a rare occurrence, but can result in costly damage. An optional low oil pressure switch set at about 15 psig (1 bar-g) may be installed to shut down the compressor in the event of a lubrication failure. A 10 second delay timer should be used to lock the low oil pressure switch out during compressor startup.



# INSTALLATION

## PRESSURE SWITCHES

Pressure switches may be installed in the suction or discharge gas stream as protective devices, for compressor control, or for other uses varying with each application and system design.

## PRESSURE GAUGES

Install pressure gauges in the discharge and inlet lines to verify actual suction and discharge pressures.

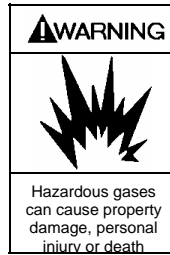

**OPTIONAL LIQUID TRAP LEVEL SWITCHES, TEMPERATURE SWITCHES, PRESSURE SWITCHES OR OTHER ELECTRICAL DEVICES MUST BE PROPERLY SPECIFIED FOR APPLICATIONS USING EXPLOSIVE GASES.**

# OPERATION

## PRE-STARTUP CHECK LIST

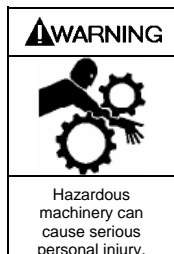

**FAILURE TO DISCONNECT AND LOCKOUT ELECTRICAL POWER OR ENGINE DRIVE BEFORE ATTEMPTING MAINTENANCE CAN CAUSE SEVERE PERSONAL INJURY OR DEATH**

1. After the compressor is installed in the system, a complete leak test **MUST** be performed on both the compressor and the piping.

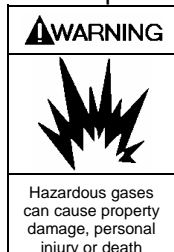

**FAILURE TO PROPERLY LEAK TEST THE COMPRESSOR INSTALLATION MAY RESULT IN LEAKAGE OF EXPLOSIVE GAS TO THE ATMOSPHERE CREATING AN EXPLOSION HAZARD, POSSIBLY CAUSING SEVERE PERSONAL INJURY OR DEATH.**

2. Re-check the system piping and the piping supports to ensure that no piping loads are being placed on the compressor.



**DISCHARGE PIPING SURFACE TEMPERATURES MAY BE HOT DURING OPERATION (OVER 158°F, 70°C). TEMPERATURES SHOULD BE MONITORED AND ADEQUATE WARNINGS POSTED.**

3. If V-belt driven, check the alignment of the motor and the compressor sheaves. The faces of the sheaves must be parallel.
4. Ensure that pressure gauges are installed on both inlet and discharge of the compressor.

5. Blackmer compressors are shipped from the factory without oil in the crankcase. Fill with a high quality non-detergent oil of the proper viscosity. See "Crankcase Lubrication" in this manual.
6. Check the electrical connections for proper wiring, grounding, etc.
7. With the power disconnected, remove the compressor nameplate. Squirt oil onto each crosshead while rotating the compressor by hand to verify smooth operation.
8. Ensure that all guarding is properly installed.

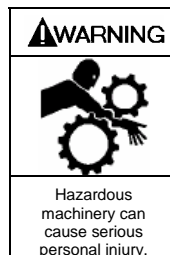

**OPERATION WITHOUT GUARDS IN PLACE CAN CAUSE SERIOUS PERSONAL INJURY, MAJOR PROPERTY DAMAGE OR DEATH.**

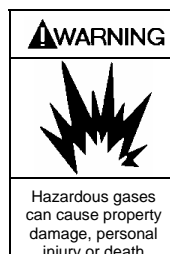

**FLYWHEEL GUARD CONTACT WITH MOVING PARTS MAY BE A SOURCE OF IGNITION IN EXPLOSIVE ATMOSPHERES CAUSING SEVERE PERSONAL INJURY OR DEATH**

# OPERATION

## STARTUP PROCEDURE

### NOTICE:

CONSULT THE 'TROUBLESHOOTING' SECTION OF THIS MANUAL IF DIFFICULTIES DURING STARTUP ARE EXPERIENCED.

1. Start the compressor. Oil pressure should register 25 psig (172 kPa) within 10 seconds.

**If proper oil pressure is not present, stop the compressor and correct the problem.**

Operating the compressor with low oil pressure will cause severe damage to the unit. Adjust if necessary. See "Setting the Oil Pressure".

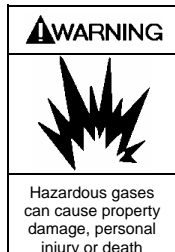

**OPERATION OF THE COMPRESSOR WITH LOW OR NO OIL MAY RESULT IN EXTREME TEMPERATURE IN THE CRANKCASE. THIS COULD BE AN IGNITION SOURCE IN THE PRESENCE OF EXPLOSIVE GAS AND COULD LEAD TO SEVERE PERSONAL INJURY OR DEATH.**

The oil pump on these models will operate in either direction of crankshaft rotation.

2. Verify that the suction and discharge pressures are within the expected ranges.

**Operating limits listed in the "Compressor Data" section must not be exceeded.**

3. Check for leakage from the piping and equipment, and repair as necessary.
4. If the seals (packing) have just been replaced or if the compressor has been out of service for over 6 months, the lower seal **MUST** be manually lubricated during the first 60 minutes of operation. See "Seal (Packing) Replacement" section. New compressors have had the packing broken in at the factory.
5. On newly rebuilt units, the valve hold down screws, valve cover plate bolts and cylinder head bolts **MUST** have their torque checked after 60 minutes running time. Also re-tighten all hold down bolts, flywheel bolts, etc. after 60 minutes running time. See Table 7 - "Bolt Torque."

## MAINTENANCE

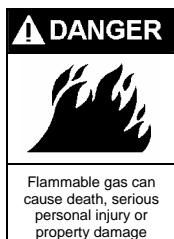

**FLAMMABLE GAS AND/OR LIQUID CAN FORM EXPLOSIVE MIXTURES WITH AIR CAUSING PROPERTY DAMAGE, SERIOUS PERSONAL INJURY OR DEATH**



**FAILURE TO RELIEVE SYSTEM PRESSURE PRIOR TO PERFORMING COMPRESSOR SERVICE OR MAINTENANCE CAN CAUSE SERIOUS PERSONAL INJURY OR PROPERTY DAMAGE.**

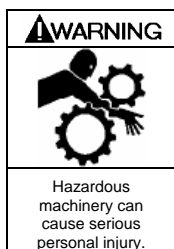

**FAILURE TO DISCONNECT AND LOCKOUT ELECTRICAL POWER OR ENGINE DRIVE BEFORE ATTEMPTING MAINTENANCE CAN CAUSE SEVERE PERSONAL INJURY OR DEATH**

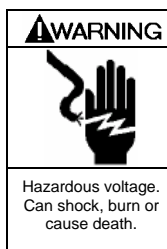

**FAILURE TO DISCONNECT AND LOCKOUT ELECTRICAL POWER BEFORE ATTEMPTING MAINTENANCE CAN CAUSE SHOCK, BURNS OR DEATH**

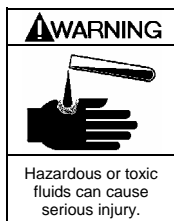

**IF HANDLING HAZARDOUS OR TOXIC FLUIDS, SYSTEM MUST BE FLUSHED AND DECONTAMINATED, INSIDE AND OUT, PRIOR TO PERFORMING SERVICE OR MAINTENANCE**



**DISCONNECTING FLUID OR PRESSURE CONTAINMENT COMPONENTS DURING COMPRESSOR OPERATION CAN CAUSE SERIOUS PERSONAL INJURY, DEATH OR MAJOR PROPERTY DAMAGE**

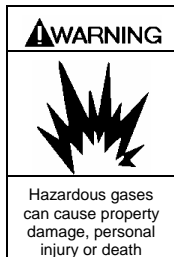

**EXPLOSIVE GAS CAN CAUSE PROPERTY DAMAGE, PERSONAL INJURY, OR DEATH.**



**EXTREME HEAT CAN CAUSE PERSONAL INJURY OR PROPERTY DAMAGE**

## MAINTENANCE

### NOTICE:

**Blackmer compressor service and maintenance shall be performed by qualified technicians only. Service and maintenance shall conform to all applicable local and national regulations and safety standards.**

### SERVICE SCHEDULE

	Daily	Weekly	Monthly	6 Months	Yearly
Overall Visual Check	X				
Check Crankcase Oil Pressure	X				
Check Suction Pressure	X				
Check Discharge Pressure	X				
Drain Drainage Piece (Double-Seal Models)		X			
Drain Liquid From Accumulation Points		X			
Clean Compressor Cooling Fins		X			
Check Crankcase Oil Level *			X*		
Check Mounting and Anchor Bolts			X		
Check V-Belt Tension			X		
Change Oil and External Oil Filter *				X*	
Check Inlet Filter/Strainer Element				X	
Inspect Valves				X	
Lubricate 4-way Valve				X	
Lubricate Motor Bearings per Manufacturer's Suggestions				X	
Inspect Motor Starter Contact Points					X
* Change oil every 1,000 hours of operation, or every 6 months whichever ever occurs first. If the oil becomes unusually dirty, change oil and external filter as often as needed to maintain clean oil.					

**Table 5 - Service Schedule**

### TOOL LIST

Description	Used For:
Blackmer Wrench 790535	Valve Hold-down screw
Blackmer Packing Installation Tool 790536 for 160 and 360 Series Compressors 790538 for 600 Series Compressors	Rod-packing protection during installation.
3" Adjustable Spanner with 1/4" pins (Blackmer PN 790316)	Piston Nut, Piston, Packing Box Hold-down Ring
9/16", 5/8" or 3/4" End Wrench	Cylinder and Crosshead Guide
1-1/16" Wrench or Socket	Valve Caps
Allen Wrenches: 3/16", 1/4", 3/8"	Valves
Sockets: 7/16", 1/2", 9/16", 5/8", 3/4", 7/8"	Various
Internal Snap Ring Pliers	Seal Replacement
Feeler gauges or Depth Micrometer	Piston Clearance
Screwdriver, Flat Blade	Nameplate screws, Packing Installation
Pliers	
Rubber Mallet	
Arbor Press	Wrist Pin Removal
Bearing Puller	Crankshaft Bearings
Torque Wrench	Various
Hoist (useful)	Cylinder and Crosshead Guide

**Table 6 - TOOL LIST**

# MAINTENANCE

## BOLT TORQUES FOR BLACKMER COMPRESSORS LBS-FT (Nm)

Size	Connecting Rod Bolt	Bearing Carrier	Bearing Cover Plate	Crankcase Inspection Plate	Crosshead Guide	Cylinder	Head	Piston Nut	Valve Cover Plate	Valve Hold Down Screw	Valve Cap
160	30 (40.7)	30 (40.7)	35 (47.5)	7 (9.5)	25 (33.9)	25 (33.9)	20 (27.1)	40 (54)	--	120 (163)	80 (108)
360	35 (47.5)	30 (40.7)	35 (47.5)	7 (9.5)	35 (47.5)	35 (47.5)	40 (54)	40 (54)	35 (47.5)	80 (108)	80 (108)
600	45 (61)	30 (40.7)	40 (54)	7 (9.5)	40 (54)	40 (54)	40 (54)	60 (81)	35 (47.5)	80 (108)	80 (108)

**Table 7 - Bolt Torque**

### CRANKCASE LUBRICATION

Change the crankcase oil every 1,000 hours or 180 days, whichever is shorter. Under severe dusty or sandy operating conditions, the oil should be changed every 500 hours or every 90 days.

A high quality non-detergent oil is recommended. **The oil used should be of high quality such as API grade SF, SG, SH or similar. API grade SA, SB, SC or similar oils should never be used. Recycled oils should never be used.**

Consult factory for special lubricating requirements.

Before changing the oil, bring the compressor up to normal operating temperature. Remove the crankcase drain plug and drain the oil into an adequately sized container. Remove the oil pickup screen and clean in a suitable solvent. When reinstalling the pickup screen, inspect the metal gasket and the O-ring for damage, replacing as necessary. If equipped, replace the external oil filter. See Figure 8.

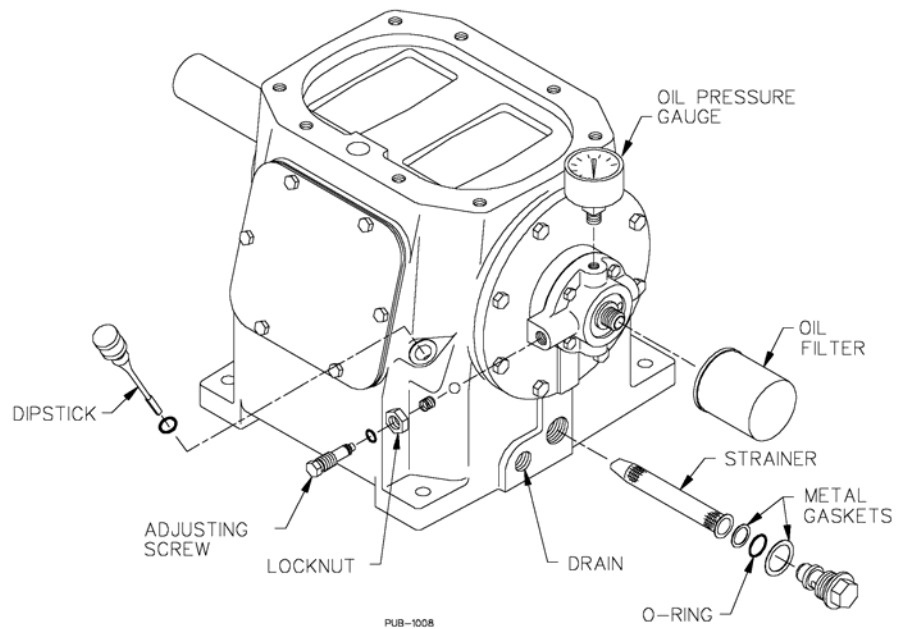

**Figure 8 - Compressor Lubrication System**

Refill the crankcase via the dipstick opening. **DO NOT OVERFILL THE CRANKCASE!**

The oil pump on these models will operate in either direction of crankshaft rotation.

Models	Quarts
LB161B, LB162B	2
LB361B, LB362C	3
LB601B, LB602B	7

**Table 8 - Oil Capacity**

### SETTING THE OIL PRESSURE (see Figure 8)

- The oil pressure should be about 25 psig (173 KPa).
- Loosen the locknut.
- Increase the pressure setting by turning the adjusting screw inward, **CLOCKWISE**.  
Decrease the pressure setting by turning the adjusting screw outward, **COUNTER-CLOCKWISE**.
- Retighten the locknut.

Air Temperature	Oil Viscosity
Below 0°F (-18°C)	SAE 5W
0 to 32°F (-18 to 0°C)	SAE 10W
32 to 80°F (0 to 27°C)	SAE 20W
80°F (27°C) and above	SAE 30W

**Table 9 - Oil Viscosity**

## COMPRESSOR DISASSEMBLY

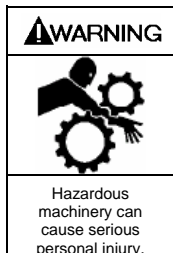

**FAILURE TO DISCONNECT AND LOCKOUT ELECTRICAL POWER OR ENGINE DRIVE BEFORE ATTEMPTING MAINTENANCE CAN CAUSE SEVERE PERSONAL INJURY OR DEATH**

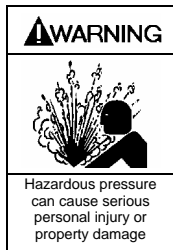

**FAILURE TO RELIEVE SYSTEM PRESSURE PRIOR TO PERFORMING COMPRESSOR SERVICE OR MAINTENANCE CAN CAUSE SERIOUS PERSONAL INJURY OR PROPERTY DAMAGE.**

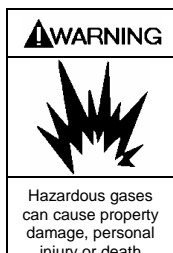

**VENTING PRESSURE FROM THE COMPRESSOR PIPING COULD RELEASE EXPLOSIVE GAS TO THE ATMOSPHERE CREATING AN EXPLOSION HAZARD, POSSIBLY CAUSING SEVERE PERSONAL INJURY OR DEATH.**

### NOTICE:

**Before starting work on the compressor, make sure all pressure is bled off on both the suction and discharge.**

1. Remove the center head capscrews from the cylinder head. Remove the outer cylinder head capscrews.
2. Remove the cylinder head assembly and cylinder head O-rings from the cylinder. The suction and discharge valve assemblies will come off with the cylinder head. For valve replacement instructions, refer to the "Valve Replacement" section of this manual.
3. Removal of the piston requires a 3" adjustable spanner wrench with 1/4" pins, such as Blackmer PN 790316.
  - a. Rotate the flywheel by hand to bring a piston to top dead center of the cylinder.
  - b. Remove the piston nut by turning the nut counterclockwise. (The nylon locking insert in the piston nut must be replaced during reassembly.)
  - c. To remove the piston from the cylinder, turn it counterclockwise with the use of the adjustable spanner wrench. For removal and replacement of the piston rings, refer to the "Compressor Assembly" section.
  - d. Remove the thrust washer and any shims. Keep the shims and piston together.
  - e. Repeat these steps for the other piston.
4. Remove the cylinder capscrews.
5. Lift the cylinder and cylinder O-rings from the crosshead guide (or distance piece).

6. Packing Box Removal
  - a. Using an adjustable spanner wrench, remove the packing box hold-down rings. (Replace the nylon locking inserts in the hold-down rings during reassembly.)
  - b. Remove the packing box and packing box O-ring from each piston rod. Double-Seal models will have a spacer ring and a second packing box O-ring to remove from each piston rod.
  - c. For disassembly of the packing boxes, refer to the "Seal (Packing) Replacement" section of this manual.
7. Remove the crosshead guide capscrews, and lift the crosshead guide and gasket off.
8. To remove the connecting rod assemblies, with the crossheads attached, it may be necessary to drain the oil from the crankcase. The piston rod is permanently attached to the crosshead to form a single assembly. Do not attempt disassembly.
  - a. Remove the inspection plate from the crankcase.
  - b. Remove the locknuts from the connecting rod bolts. This will release the connecting rod cap (the lower half of the connecting rod) and the two halves of the bearing insert. The connecting rod and the connecting rod cap are marked with a dot on one side so that they can be properly aligned when reassembling.
  - c. Lift the crosshead assembly and connecting rod off the top of the crankcase.

### NOTICE:

**The connecting rod parts are not interchangeable and must be reassembled with the same upper and lower halves. To avoid confusion, work on one connecting rod at a time, or mark the individual halves with corresponding numbers.**

9. Remove the opposite connecting rod and crosshead assembly in the same manner as outlined in step 8.
10. Rest the crosshead assembly on a bench. Carefully drive the wrist pin and wrist pin plugs out of the crosshead and connecting rod using a suitable pin driver or an arbor press. Removal of the pin releases the crosshead assembly from the connecting rod.
11. If necessary, the wrist pin bushings can be replaced after the crossheads are removed. New bushings must be honed to the proper size after installation.

## COMPRESSOR DISASSEMBLY

12. To replace the crankshaft bearings, the crankcase must be disassembled, and the crankshaft removed. Refer to the "Bearing Replacement" section of this manual.

Compressor Model	Bushing I.D. Inches (mm)
LB161B, LB162B LB361B, LB362C	0.8753 to 0.8756 (22.233 to 22.240)
LB601B, LB602B	1.2511 to 1.2514 (31.778 to 31.786)

Table 10 - Wrist Pin Bushing Dimensions

## COMPRESSOR ASSEMBLY

Compressor assembly is generally the opposite of compressor disassembly. Before reassembling, clean each part thoroughly. Check all machined surfaces for burrs or roughness, and file lightly if necessary. **Replace any O-rings or gaskets that are removed or disturbed during service.**

### 1. CRANKCASE ASSEMBLY

After replacing the crankshaft, bearing carrier, and bearing cover plate, the connecting rod and crosshead can be assembled in the crankcase. See the "Bearing Replacement" section.

- a. To attach the connecting rod to the crosshead assembly, first coat the wrist pin, the wrist pin bore in the crosshead assembly, and the wrist pin bushing in the connecting rod with grease.
- b. Start the wrist pin in the bore of the crosshead assembly and tap lightly until the pin begins to project through to the inside of the crosshead assembly.
- c. Slide the connecting rod up inside of the crosshead assembly and align the bushing with the wrist pin.
- d. Lightly tap the wrist pin through the connecting rod until it is centered in the crosshead assembly. The wrist pin should be snug in the crosshead assembly. The connecting rod should rotate freely on the wrist pin, but should not be loose.
- e. Dip the wrist pin plugs in grease and press them against the ends of the wrist pin.
- f. Place the bearing halves into each half of the connecting rod, aligning the bearing tangs with the slots in the connecting rod. Coat the bearing with grease.
- g. Set the top of the connecting rod over the crankshaft journal. Replace the connecting rod cap with the dots on the connecting rod and cap on the same side.
- h. Start the nuts on the connecting rod bolts and torque per Table 7 - "Bolt Torque."
- i. Follow this same procedure for the opposite connecting rod.

### 2. CROSSHEAD GUIDE

- a. Place the crosshead guide gasket on top of the crankcase.
- b. Lubricate the inside bore of the crosshead guide with light oil.
- c. Set the crosshead guide over the piston rods and the crossheads, and slowly lower it against the crankcase. Make certain that the crosshead assemblies are started straight in the bores of the crosshead guide to prevent binding when lowering the crosshead guide into position.
- d. Install the crosshead guide capscrews. **DO NOT** tighten.

3. Fill the crankcase with oil. Refer to the "Crankcase Lubrication" section. Squirt oil into the crankshaft, roller bearings, crankshaft journals, and crosshead assemblies to ensure proper lubrication at start up.
4. Attach the inspection plate and the inspection plate gasket to the crankcase.

### 5. PACKING BOX ASSEMBLIES

Before installing the packing boxes into the crosshead guide, inspect the piston rods for scoring or roughness. Remove any burrs or sharp edges. Lubricate the piston rods and packing box O-rings with light oil. **Do not damage the packing when starting it over the rod. Use of a Blackmer packing installation tool is recommended.**

#### Single-Seal Models

- a. Insert the packing box O-ring into the crosshead guide.
- b. Start the packing box assembly, short end down, over the piston rod and into the counter-bored hole of the crosshead guide.
- c. Install the packing box retainer ring, with new nylon locking inserts, and tighten securely.
- d. Repeat the above steps for the remaining packing box.

#### Double-Seal Models

- a. Insert the lower packing box O-ring into the crosshead guide.
- b. Start the packing box assembly, short end down, over the piston rod and into the crosshead guide.

## COMPRESSOR ASSEMBLY

- c. After the lower set of packing is started over the piston rod, make sure the oil deflector ring is properly aligned (with the flat side down) over the piston rod. Use the hole in the side of the packing box to center the deflector ring. Once the deflector ring is over the rod, the packing box can be fully inserted.
- d. Install the upper packing box O-ring on the end of the packing box.
- e. Place the packing box spacer ring over the O-ring.
- f. Install the packing box retainer ring, with new nylon locking inserts, and tighten securely.
- g. Repeat the above steps for the remaining packing box.

6. Rotate the crankshaft by hand a few times, then uniformly tighten the crosshead guide capscrews per Table 7 - "Bolt Torque."

7. Break in new packing per the "Seal (Packing) Replacement" section of this manual.

### 8. CYLINDER ASSEMBLY

- a. Install new O-rings in the bottom of the cylinder. A small amount of grease may be used to hold the O-rings in place during assembly.
- b. Set the cylinder over the piston rods and against the crosshead guide.
- c. Install the cylinder capscrews. DO NOT tighten.

### 9. PISTON RINGS

- a. Place an expander in the top groove of the piston. Place an expander in the second groove with the break in this expander 180 degrees from the break of the top expander. Place the third expander in the bottom groove with its break in the same position as the top expander.
- b. Place piston rings in all three grooves of the piston. Align the breaks in the piston rings directly opposite the breaks in the corresponding expanders.

### 10. PISTONS

- a. Rotate the flywheel by hand to bring one piston rod to top dead center of the cylinder assembly.
- b. Set the thrust washer and one shim on the shoulder of the piston rod.
- c. With light pressure, squeeze the piston rings inward while threading the piston clockwise onto the rod. Tighten with the 3" adjustable spanner wrench.
- d. Follow this same procedure for the second piston.
- e. Rotate the crankshaft by hand a number of times to verify that the pistons are centered in the cylinder bores. Adjust the cylinder so that the pistons DO NOT touch the cylinder walls.
- f. Using an alternating pattern, torque the cylinder capscrews per Table 7 - "Bolt Torque."

### 11. PISTON CLEARANCE

- a. Rotate the flywheel by hand to bring one piston to the top.
- b. Measure the distance from the top of the piston to the top of the cylinder.

LB161B	.010" to .025" (.254 to .635 mm)
LB162B	.015" to .030" (.381 to .762 mm)
LB361B	.020" to .035" (.508 to .889 mm)
LB362C	.025" to .040" (.635 to 1.016 mm)
LB601B	.020" to .035" (.508 to .889 mm)
LB602B	.030" to .045" (.762 to 1.143 mm)

**Table 11 - Piston Clearance**

- c. If necessary, remove the piston and add or subtract shims accordingly.
- d. Install new nylon locking inserts in the piston retainer nuts.
- e. Thread the piston nut onto the piston rod and tighten securely with the spanner wrench.
- f. Follow this same procedure for the second piston.

### 12. CYLINDER HEAD ASSEMBLY

If the valve assemblies have been removed from the cylinder head, refer to the "Valve Replacement" section of this manual.

- a. Place the cylinder head O-rings in the grooves located on top of the cylinder.
- b. Place the cylinder head assembly on top of the cylinder.
- c. Hand tighten the outer capscrews and center capscrews into the cylinder head.
- d. Gaskets MUST be used on the center capscrews of the LB161 and LB162 models.
- e. Uniformly torque the cylinder head capscrews per Table 7 - "Bolt Torque."

13. Rotate the compressor by hand to verify that it turns freely. Ensure that the pistons are not hitting the cylinder head assembly.

14. Follow all procedures listed in the "Pre-Startup Check List" and "Startup Procedure" sections of this manual.

15. Start the compressor and bring to normal operating temperature. Stop the compressor, allow it to cool and retorque the valve hold down screws per Table 7 - "Bolt Torque."



## VALVE REPLACEMENT

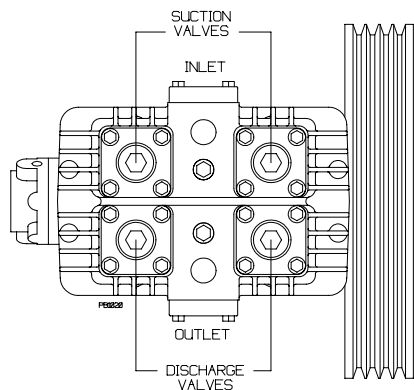

**Figure 9 - Valve Location**

Suction and discharge valves **MUST** be installed in the correct cylinder head locations. See Figure 9.

The valves may be removed without removing the cylinder head from the cylinder. Be sure to remove and replace the valve gaskets.

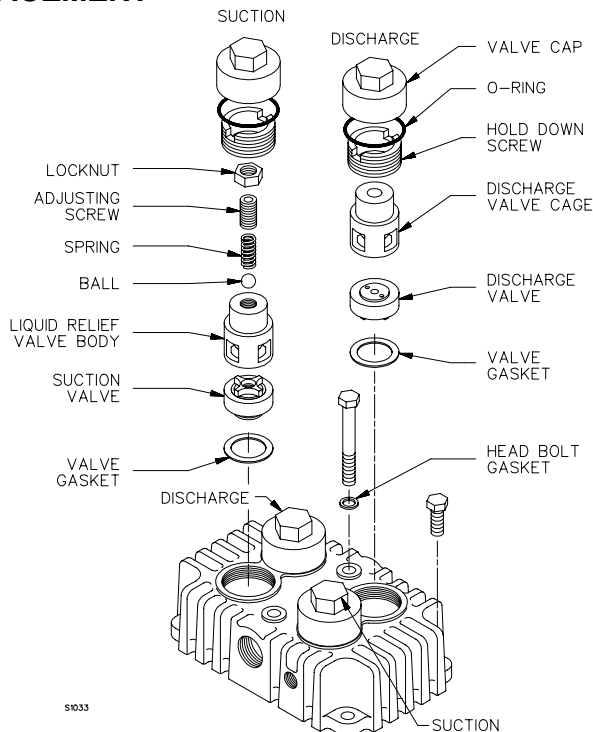

**Figure 10 - LB161 or LB162 Valves**

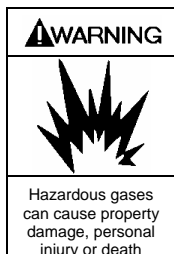
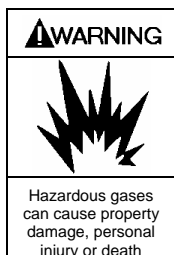
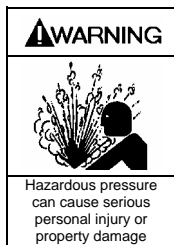

**MODELS LB161B or LB162B** - see Figure 10.

1. Remove the valve cap and O-ring from the valve being serviced.
2. Remove the valve hold down screw with a spanner wrench, such as Blackmer PN 790535.
3. Suction valve - Remove the liquid relief valve body, valve assembly and gasket. **DO NOT** drop the liquid relief ball and spring into the head interior.
4. Discharge valve - Remove the discharge valve cage, valve assembly and gasket.
5. Inspect the valve for wear or breakage.
6. Ensure that the old gasket is removed, then install a new valve gasket.
7. To reinstall the suction valves:
  - a. Install the valve assembly in the cylinder head. Ensure the correct orientation and location of the valve.
  - b. Center the liquid relief body on the valve assembly.
  - c. Install the hold down screw and tighten per Table 7 - "Bolt Torque."
  - d. Drop the liquid relief ball and the liquid relief spring into the opening of the liquid relief body.
  - e. Insert the liquid relief adjusting screw and adjust clockwise until the top of the screw is approximately 3/8" (9.5 mm) above the top of the liquid relief body. Add the locknut and tighten securely.
8. To reinstall the discharge valves:
  - a. Install the valve assembly in the cylinder head. Verify the correct valve orientation and location.
  - b. Center the valve cage on the valve assembly.
  - c. Install the hold down screw and tighten per Table 7 - "Bolt Torque."
9. Install the valve cap and O-ring. A little oil or grease on the O-ring will help hold it in place during installation.
10. After replacing the valves, rotate the flywheel by hand to check for interference between the pistons and the valves.
11. After 60 minutes running time, remove the valve cap and retorque the hold down screw. Replace the valve cap and O-ring.

## VALVE REPLACEMENT

### MODELS LB361B, LB362C, LB601B or LB602B

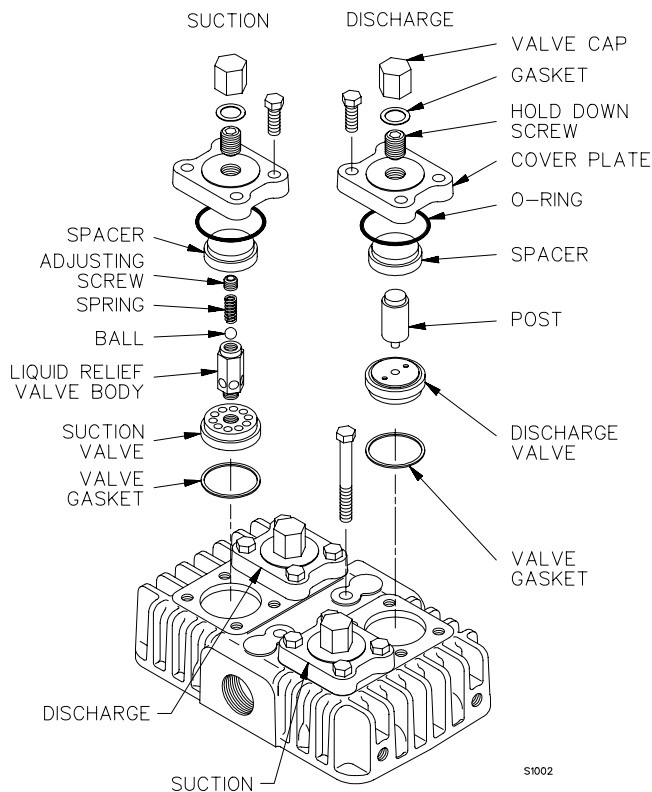

**Figure 11 -  
LB361, LB362, LB601 & LB602 Valves**

1. Remove the valve cap and gasket from the valve being serviced.
  2. **Remove** the valve hold down screw with an allen wrench.
  3. Remove the valve cover plate capscrews then lift off the cover plate and O-ring.
  4. Suction valves: remove the spacer, suction valve assembly and valve gasket.
  5. Discharge valves: remove the spacer, post, discharge valve, and valve gasket.
  6. Inspect the valve for wear or breakage. Repair or replace as necessary.
7. To reinstall the suction valves:
    - a. Adjust the liquid relief valve adjusting screw clockwise until the screw is flush with the top of the liquid relief valve body, or no more than 1/16" (1.6 mm) above the top of the liquid relief valve body.
    - b. Ensure that the old gasket is removed, then install a new valve gasket.
    - c. Install the valve assembly with the liquid relief valve upward. Verify the correct valve orientation and location.
    - d. Install the valve spacer.
    - e. Ensure the valve hold down screw is removed from the cover plate, then place the cover plate and new O-ring in position.
    - f. Install the valve cover plate capscrews and tighten per Table 7 - "Bolt Torque."
    - g. Install and tighten the hold down screw per Table 7 - "Bolt Torque."
    - h. Install the valve cap with a new gasket.
  8. To reinstall the discharge valves:
    - a. Ensure that the old gasket is removed, then install a new valve gasket.
    - b. Install the valve assembly with the plug downward. Verify the correct valve orientation and location.
    - c. Install the valve post, small end first.
    - d. Install the valve spacer.
    - e. Ensure the valve hold down screw is removed from the cover plate, then place the cover plate and new O-ring in position.
    - f. Install the valve cover plate capscrews and tighten per Table 7 - "Bolt Torque."
    - g. Install and tighten the hold down screw per Table 7 - "Bolt Torque."
    - h. Install the valve cap with a new gasket.
  9. After replacing the valves, rotate the flywheel by hand to check for interference between the pistons and the valves.
  10. After 60 minutes running time, remove the valve cap and re-torque the hold down screw. Replace the valve cap and gasket.

## SEAL (PACKING) REPLACEMENT

Follow steps 1 through 6 of the "Compressor Disassembly" section of this manual.

1. Remove the upper and lower retainer ring from the packing box being serviced. Disassemble the packing box and discard the old packing sets and packing springs.

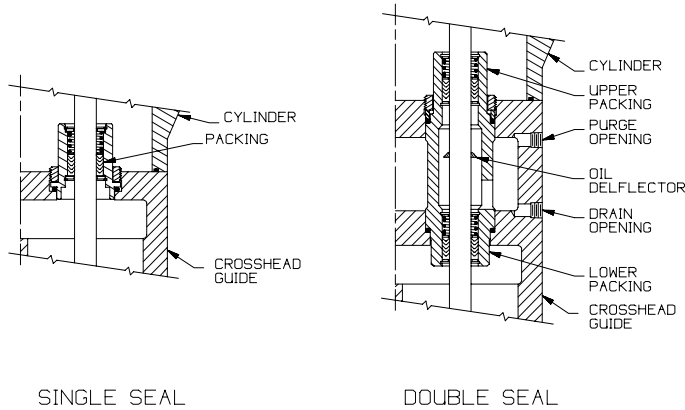

Figure 12 - Typical Seal Assembly

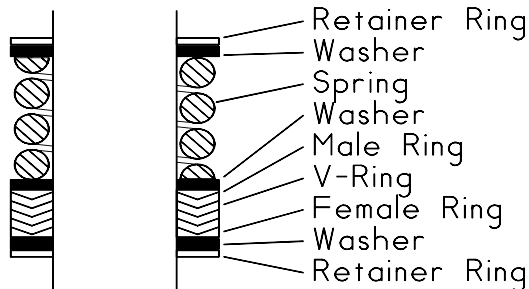

Figure 13 - TYPE 1 Seal Orientation

2. Clean the packing box in a suitable solvent. Inspect the bore for wear, roughness, or corrosion. Clean or replace as necessary.
3. Ensure that the 6<sup>th</sup> digit of the Compressor ID number is a "1", indicating a TYPE 1 packing arrangement. See "Nameplate Data" in this manual. Refer to Figures 12 and 13 for proper TYPE 1 component location and orientation.
4. **Single-Seal Packing Boxes**
  - a. Install the lower retainer ring.
  - b. Install the packing rings, spring, washers, and the upper retainer ring. To ease installation on the second retainer ring, use a screwdriver handle and press on the last washer to compress the seal spring slightly.
5. **Two-Seal Packing Boxes**
  - a. Install the inner retainer ring of the lower packing.

- b. Install the packing rings, spring, washers, and the second retainer ring. To ease installation on the second retainer ring, use a screwdriver handle and press on the last washer to compress the seal spring slightly.
- c. Insert the oil deflector ring through the top of the packing box, flat side down, into the cavity between the upper and lower packing. The oil deflector ring will be positioned between the two sets of packing.
- d. Install the upper packing set starting with the inner retainer ring.

### 6. Packing Break-in

The lower packing **MUST** be manually lubricated with oil several times during the first 60 minutes of compressor operation to prevent overheating of the piston rods and potential damage to the packing material.

To lubricate the packing:

- a. Remove the inspection plate from the crosshead guide.
- b. Run the compressor for 5 minutes then **stop** the compressor for 5 minutes to allow adequate cooling of the piston rods.
- c. Using a small oil can, lubricate the piston rods each time the compressor is **stopped**.

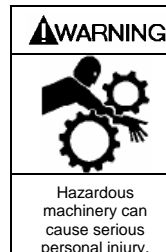

**DO NOT INSERT OBJECTS OR FINGERS IN INSPECTION CAVITY. CAN CAUSE SEVERE PERSONAL INJURY**

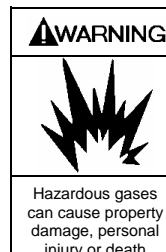

**IMPROPER SEAL INSTALLATION COULD RELEASE EXPLOSIVE GAS TO THE ATMOSPHERE CREATING AN EXPLOSION HAZARD, POSSIBLY CAUSING SEVERE PERSONAL INJURY OR DEATH.**

7. Proceed according to steps 5 through 15 of the "Compressor Assembly" section.

## BEARING REPLACEMENT

**NOTICE:** When replacing the bearings, the entire bearing assembly, including the bearing cup and the bearing cone, must be replaced.

1. Follow steps 1 through 12 of the "Compressor Disassembly" section.
2. Remove the Oil Pump per the section titled "Oil Pump Replacement."
3. Remove the flywheel.
4. Remove the bearing carrier and gasket from the outboard end of the crankcase. The outboard bearing cup will come off with the bearing carrier and will need to be removed with a bearing removal tool.
5. Remove the key from the crankshaft and slide the crankshaft through the outboard end of the crankcase. The bearing cones can then be removed with a bearing puller.
6. Remove the bearing cover plate from the inboard end of the crankcase. The inboard bearing cup is pressed into the crankcase and can be removed with the use of a bearing removal tool.
7. To install the bearings:

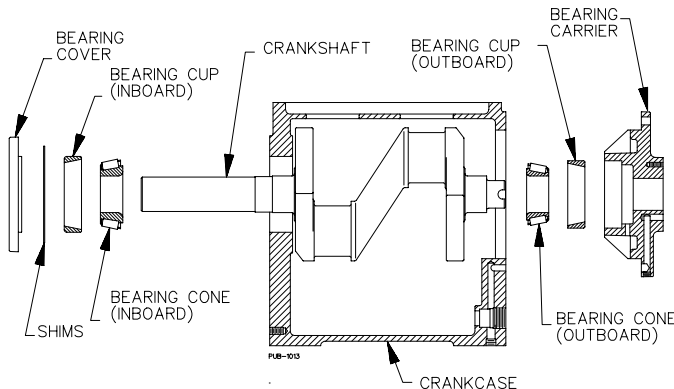

**Figure 14 - Bearing Locations**

- a. Grease the outer edges of the bearing cups.
- b. Referring to Figure 14 for the proper orientation, carefully press the inboard bearing cup into the crankcase until it is flush with the outer surface of the crankcase.

- c. Note the proper orientation and carefully press the outboard bearing cup into the bearing carrier assembly.
  - d. Press a bearing cone onto each end of the crankshaft with the tapered end outward. The bearing race should rest against the shoulder on the crankshaft.
  - e. Lubricate the bearings with grease.
8. Install the crankshaft through the outboard end of the crankcase.
  9. With the oil pump assembly removed, install the bearing carrier and new gasket. The bolt hole positions ensure proper orientation. Tighten the bolts evenly per Table 7 - Bolt Torque."
  10. If the bearings have not been replaced, reinstall the inboard bearing cover plate using the existing shim set. If the bearings have been replaced, use a **thicker** set of shims.
  11. Rotate the crankshaft by hand to verify free movement of the shaft.
    - a. If the crankshaft has an excessive amount of end play, too many shims have been used. Lateral crankshaft movement (end play) between the bearings should be 0.0015 to 0.0030" (0.038 to 0.076 mm) . If necessary, remove shims until the end play is within tolerance.
    - b. If the crankshaft binds, or will not turn, not enough shims have been used pushing the bearing cup too tight against the bearing cone. Remove the crankshaft from the crankcase and drive the inboard bearing cup out toward the inboard side of the crankcase. Reinstall the crankshaft and the bearing cover plate using additional shims as required.
  12. Install the oil pump per the "Oil Pump Replacement" section of this manual.
  13. Reassemble the compressor according to the "Compressor Assembly" section.

## OIL PUMP REPLACEMENT

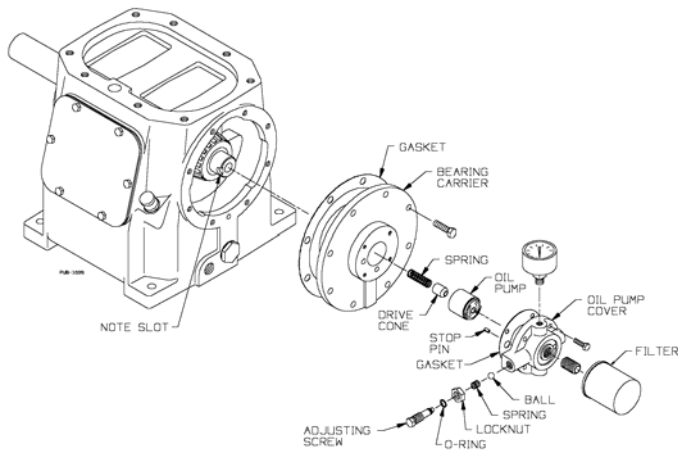

Figure 15 – Oil Pump

1. Remove the oil pump cover bolts and oil pump cover.
  2. Remove the oil pump assembly, drive cone and spring.
  3. Clean and inspect parts for wear or damage, replace as necessary.
  4. Place the spring and the drive cone in the end of the crankshaft.
  5. Note the slot in the end of the crankshaft and the drive tab on the back of the oil pump assembly. Install the oil pump assembly into the bearing carrier with the tab and slot aligned.
  6. Note the groove around outer edge of the oil pump assembly and the stop pin in the oil pump cover. Position the oil pump cover and new gasket with the pin in the oil pump groove, rotating the oil pump as needed. The bolt hole positions ensure proper orientation of the oil pump cover.
  7. BY HAND, tighten the oil pump cover bolts while the pump cover is held flush with the bearing carrier.
- NOTICE: If by hand tightening, the oil pump cover cannot be drawn flush with the bearing carrier, the drive tab or the stop pin are improperly aligned. DO NOT WRENCH TIGHTEN OR THE OIL PUMP WILL BE DAMAGED.**
8. Once the oil pump cover is secured by hand, the bolts may be evenly tightened per Table 7 - "Bolt Torque."

## EXTENDED STORAGE PROCEDURES

If a compressor is not to be put into service for some time, or if a compressor is to be taken out of service for an extended period, care must be taken to protect the compressor. The following steps must be taken for both bare compressors and those already piped into a system.

**If proper storage procedures are not followed, damage to the compressor may occur. Complete compressor disassembly and replacement of rod packing, bearings and other parts may be required.**

1. Keep a written record storage procedures performed – preferably on the unit itself.
  2. Fill the crankcase with rust inhibiting oil. (New compressors leave the factory without oil.) Squirt oil on the piston rods and crossheads through the nameplate opening. Loosen the V-belts to relieve the load on the bearings. Rotate the compressor by hand a few times to distribute the oil.
  3. Plug all openings and purge the compressor with an inert gas such as nitrogen or **dry** air at about 50 psig (3.5 bar-g). This may be done at the factory if requested. Leave the compressor pressurized to prevent air or moisture from entering the unit.
- Check the unit monthly and add additional purge gas as needed.

**NOTICE: Tag the unit with a warning that it is pressurized.**

4. If a purge gas is not available, fog oil into the compressor suction while rotating the unit. Then plug all openings to keep out moisture, insects, etc.
5. **Turn the flywheel by hand a few revolutions once a month to distribute the oil.**
6. Store the unit under a plastic wrap on its wooden shipping base up off the ground. If the unit was boxed for export shipment, leave it in its box. An indoor or covered storage area is preferable.
7. **Placing the Compressor back in service.** When the compressor is to be put in service, vent the remaining purge gas and change the crankcase oil. Follow the "Pre-Startup Checklist" and "Startup Procedure" sections in this manual.

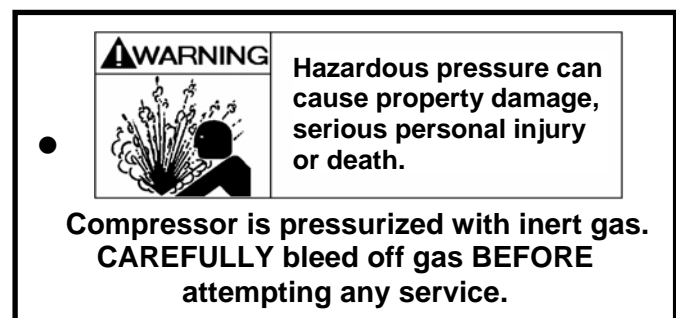

Figure 16 – Pressurized Compressor Tag

## TROUBLESHOOTING

PROBLEM	STEP	PROBABLE CAUSE	WHAT TO CHECK	IF PROBLEM STILL EXISTS GO TO STEP ...
Low Transfer Rate	1	4-Way Valve Leaking (when equipped)	Lubricate with a stick lubricant compatible with material being transferred.	2
	2	Worn or Broken Piston Rings	Check condition of rings by restricting discharge line. If pressure increases slowly, rings are probably faulty.	3
	3	Plugged Strainer	Clean screen as necessary.	4
	4	Compressor Valve Faulty	Remove and inspect for broken or worn springs, discs, or bodies.	5
	5	Liquid Relief Valves Need Adjusting	Adjust per instructions in "Valve Replacement."	6
	6	Compressor Drive Slipping	Tighten belts, check for sheared keys, loose keys or loose flywheel.	7
	7	Piping Improperly Designed or Installed	Use proper pipe sizes.	8
No Flow	8	Liquid Trap Full	Drain liquid trap through drain valve. Relieve vacuum through bleeder valve on top of liquid trap.	9
	9	Excess Flow Valves Slugged	Stop the compressor to let the excess flow open. Installation of a valved bypass line between the suction and discharge lines may be necessary.	6 & 7
Knocks or Other Noises	10	Loose Valves	Tighten valve hold-down screws.	11
	11	Worn Internal Parts	Inspect through inspection plates and repair as necessary.	4
No Oil Pressure	12	Oil Pump Relief Valve Not Properly Set.	Set oil pump relief valve.	13
	13	Oil Pump Not Working	Check the Oil Pump drive tab or stop pin for damage.	14
	14	Low Oil Level	Check and fill as necessary	15
	15	Dirty Inlet Strainer	Clean Inlet Strainer	
Gas Leaking from Crankcase Breather	16	Faulty/Worn Packing	Replace Packing.	17
	17	Piston Rod Scored	Replace crosshead assemblies and packing.	18
	18	Improper Seal Arrangement	See "Seal Arrangements."	---
Relief Valve Actuates	19	Valve Closed Downstream of the Compressor	Open Valve	20
	20	Line Blockage Downstream of the Compressor	Locate Blockage and Correct	---
Shake or Vibration	21	Loose/Broken Mounting or Anchor Bolts	See "Mounting the Compressor Unit"	22
	22	Improper Mounting	Ensure base is supported full length. See "Mounting the Compressor."	23
	23	Improperly Aligned V-belt Sheaves	See "V-Belt Drives"	24
	24	Improperly Installed Flywheel	See "Compressor Flywheel"	25
	25	Nonfunctioning Valves	Replace or repair valves.	---



## DECLARATIONS

**Blackmer, A Dover Company**  
1809 Century Avenue S.W.  
Grand Rapids, Michigan 49503-1530  
United States of America

**ATEX**  
**FORM ES-039**  
Effective April 2004  
Rev. B

### DECLARATION OF CONFORMITY

As defined by the ATEX directive 94/9/EC

Herewith we declare that all Blackmer LB and HD compressor product lines to which this declaration relates are in conformity with the provisions of the ATEX Directive 94/9/EC as of 01 July 2003. This equipment is a reciprocating compressor for liquefied gas transfer or gas compression applications. This device is not intended to act as a safety accessory.

Applied Harmonized Standards:  
EN1127-1, EN13463-1

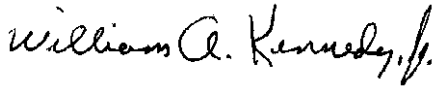

Date: April 1, 2004  
William A Kennedy Jr., P.E.  
Vice President - Engineering

### DECLARATION OF INCORPORATION

As defined by the Machinery Directive 97/37/EC

Herewith we declare that all Blackmer LB and HD compressor product lines to which this declaration relates are in conformity with the provisions of the Machinery Directive, 97/37/EC as of 01 July 2003. The above equipment is a reciprocating compressor designed for liquefied gas transfer or gas compression applications. This device is not intended to act as a safety accessory.

This component must not be operated until the machine into which it is incorporated has been declared in conformity with the provision of the directive.

Applied Harmonized Standards:  
EN1012-1, EN292

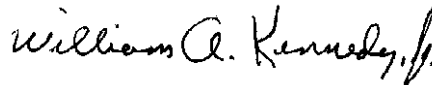

Date: April 1, 2004  
William A Kennedy Jr., P.E.  
Vice President - Engineering

### ATEX/ Machinery Directive Notifications:

**Maximum Surface Temperature:** It is the end users responsibility to ensure the compressor does not exceed the temperature limits. Closed inlet or outlet valves can result in excess compressor surface temperature conditions.

**Intended Use:** Blackmer compressors are intended for use in liquefied gas transfer or gas compression applications. The compressor must be operated in systems, with gasses and at conditions for which it is specifically designed and sized.

**Possible Misuse Warning:** The compressor must only be installed in systems designed for its intended use.

**Mechanical Ignition Sources:** Guards, intended to protect from personal injury from rotating components, must be fabricated from ATEX compliant materials to prevent a potential ignition source. The compressor and its drive system must be properly grounded to prevent electrostatic discharge. The compressor has internal parts that rub together. These parts require proper viscosity lubricant to lubricate the rubbing surfaces. Compressor must be properly maintained and lubricated, see IOM (Installation, Operation, & Maintenance Instructions) for service information.

**Sound Measurements:** Sound Levels for gas compression equipment vary greatly, depending on operating conditions, piping system design, foundation design, etc. You can expect the following sound levels when operating a Blackmer compressor at its' maximum rated speed and discharge pressure. Sound levels are measured at 1 meter from the compressor and 1.6 meters from the foundation per European Machinery Directive 98/37/EC.

Maximum Noise Level: 85 dba

**Equipment Marking:** All compressor models are classified Group II category 2, Gas and have a temperature limit of 176 °C. Compressors are marked "Ex II 2 G 176 °C MAX "

**Compressor Models Covered:** LB, HD



## NOTES

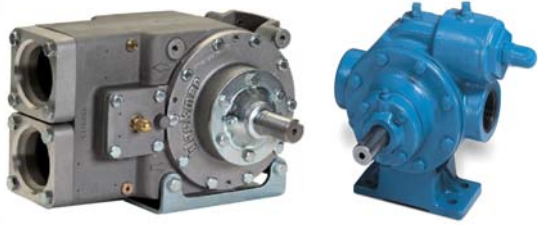

Sliding Vane Pumps: 5 to 2200 GPM  
Refined Fuels, Liquefied Gases, Process,  
Transport, Marine

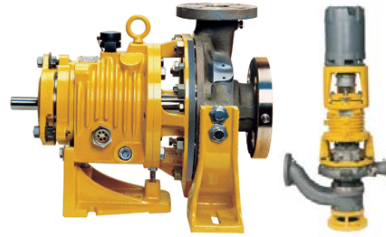

System One Centrifugal Pumps  
10 to 7500 GPM  
Process, Marine



C-Series Eccentric Disc Pumps  
1 to 150 GPM  
Shear Sensitive, Food, Process



Abaque Peristaltic Hose Pumps  
0.5 to 220 GPM  
High Lift, Solids, Abrasives



Rotary Vane and Screw Compressors  
Dry Bulk Unloading



Reciprocating Gas Compressors  
Liquefied Gas Transfer, Boosting, Vapor Recovery



Hydraulic Coolers  
Complete Packages



Magnetic Drive Pumps  
Iron and Stainless, 14 to 333 GPM



Hand Operated Pumps  
Dispensing, Transfer, In-line



Accessories  
Gear Reducers, Bypass Valves, Strainers

Visit [www.blackmer.com](http://www.blackmer.com) for complete information on all Blackmer products



1809 Century Avenue, Grand Rapids, Michigan 49503-1530 U.S.A.  
Telephone: (616) 241-1611 • Fax: (616) 241-3752  
E-mail: [blackmer@blackmer.com](mailto:blackmer@blackmer.com) • Internet Address: [www.blackmer.com](http://www.blackmer.com)